

# Burton Assembly Care and Maintenance Guide



## McClure Tables Handcrafted Shuffleboard Guide

- How to level and adjust the board
- Care and maintenance tips
- Warranty Information
  
- Installation Instructions
  - Tables can be heavy we recommend 2 to 4 or more people for larger tables
  - Recommend power drill for uncrate or remove packing material
  - Most other assembly can be done with hand tools
  - Level or straight edge can be helpful.

# Burton 9-12 foot Table Packing List

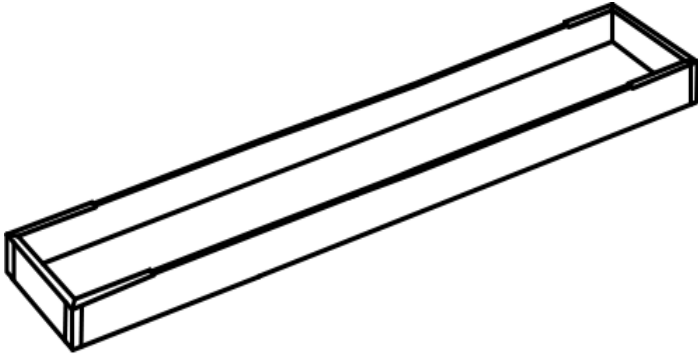

#1

1 Pcs Cabinet



#2

2 Legs

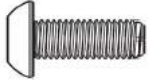

#4

10 Pcs 5/16 x 1" Allen Bolt

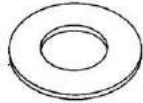

#5

8 Pcs Washers



Pack of shims Leg Levelers



#6

Center Leg Beam Stretcher

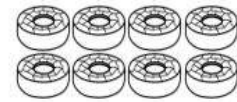
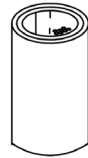

1

Pound Can of Wax  
4 Red Pucks  
4 Blue Pucks

## Assembly of the Legs and Cabinet

1. It may be easier to assemble the legs with the table upside down as shown below. Please make sure to lay down a blanket for protection or turn the table upside down on carpet.
2. Attach the legs with bolts and washers. Start each bolt by hand before tightening with a wrench.
  - a. Use 4 Bolts (#4) as shown and washers for each leg

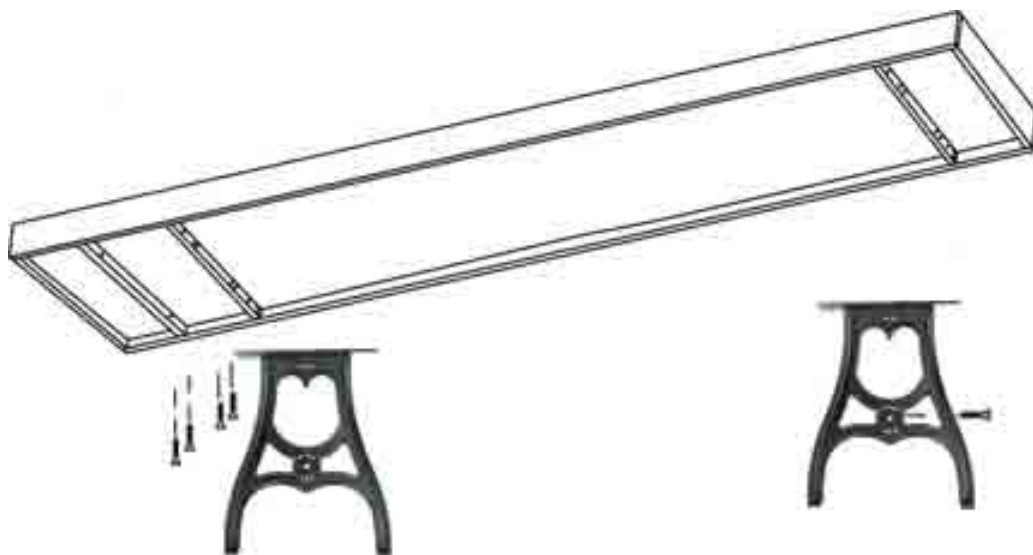

**Attach stretcher with two bolts #4 no washers are used**

## Place the Cabinet in Position

1. Lift the cabinet into the upright position and place in the location in the room where you would like the table.
  - Take care not to put too much weight on the sides of the legs as you lift or roll the table over into the upright position.

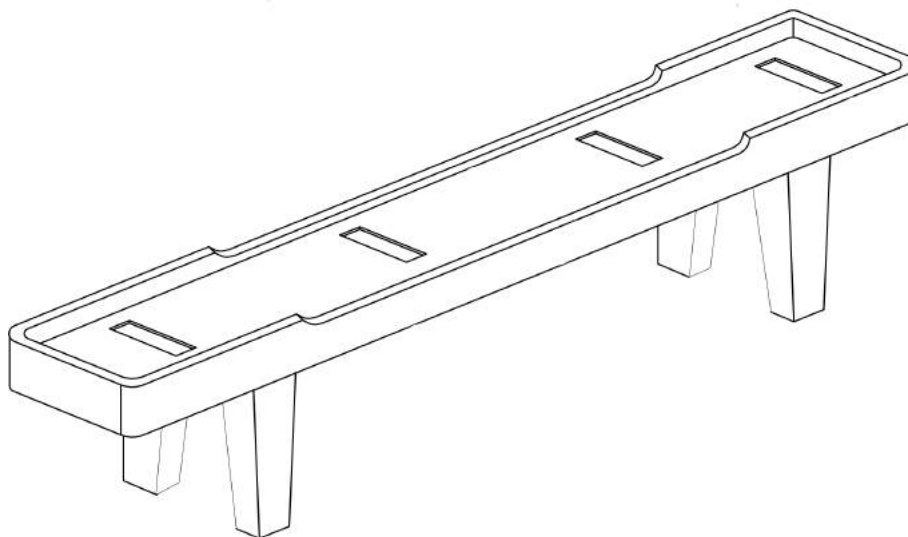

## Assembly of the Play-board into Cabinet

\*The weight of the play-board can be quite heavy, so we suggest 2 to 4 people.

1. On smaller boards or if you have plenty of help then you can follow Method A below.

\*Place board onto the cabinet. Be sure to lift the board high enough so that the climate adjusters do not hit the cabinet.

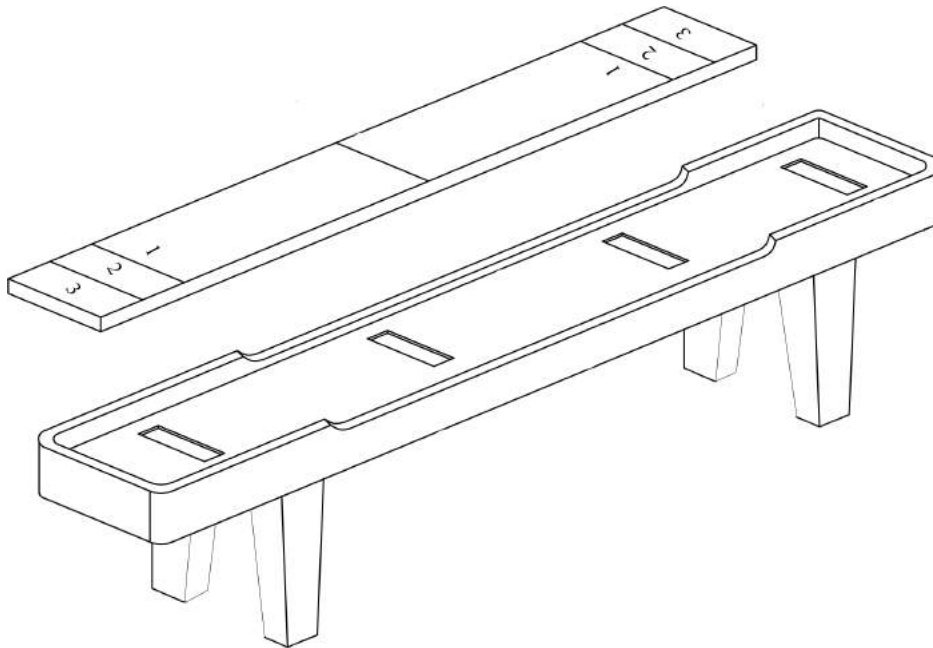

2. When working with larger boards or if you only have two people, we suggest following Method B below.

\*Place blankets or moving pads draped over one side of the cabinet and two pucks upside down on each end of the cabinet about 2" from where the end of the board is. Do not place them too far inside.

\*Roll the board over upside down and rest half on the blanket and side of the cabinet.

\*Roll the board on its edge inside the cabinet and carefully remove the blanket.

\*Roll the board over right side up and rest it on the pucks.

\*Have one person go under the table, and using the brackets as bars, bench press the end of the board while the other person removes the pucks.

