

Competitor Assembly Care and Maintenance Guide



McClure Tables Handcrafted Shuffleboard Guide

- How to level and adjust the board
- Care and maintenance tips
- Warranty Information

- Installation Instructions
 - Tables can be heavy we recommend 2 to 4 or more people for larger tables
 - Recommend power drill for uncrate or remove packing material
 - Most other assembly can be done with hand tools
 - Level or straight edge can be helpful.

Competitor 14-16 foot Table Packing List

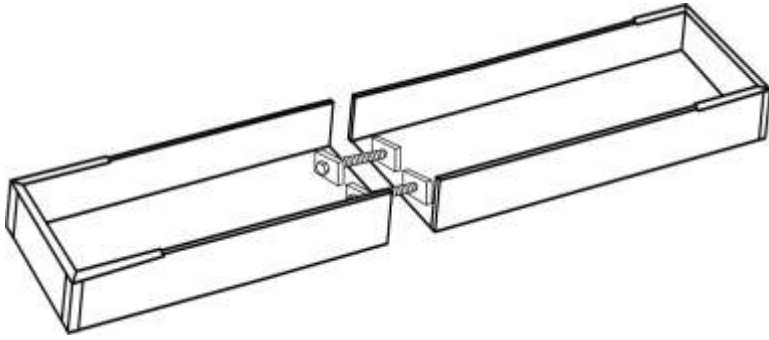

#1

**2 Pcs Cabinet
(Shipped assembled with Tite-Joints)**

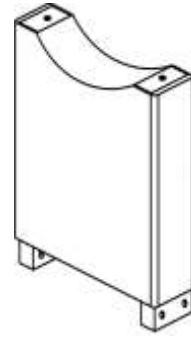

#2

3 Pcs Legs



#3

6 Pcs Leg Levelers



#4 & #5

**12 Pcs 5/16 Washer
12 Pcs 5/16 x 1 1/2" Bolt**

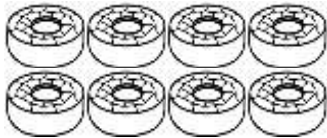

**4 Red Pucks
4 Blue Pucks**



1 Pound Can of Wax



2" Playboard

Assembly of the Legs

1. If it is more convenient to move the table in two pieces, remove the Tite-Joints to separate the halves. Reverse the process to reassemble.
2. It may be easier to assemble the legs with the table upside down as shown below. Please make sure to lay down a blanket for protection or turn the table upside down on carpet.
3. Attach the legs with bolts and washers. Start each bolt by hand before tightening with a wrench.
 - a. Use 2 Bolts (#5) with 2 Washers (#4) as shown.
 - b. Attach a Leg Leveler (#3) to each foot.

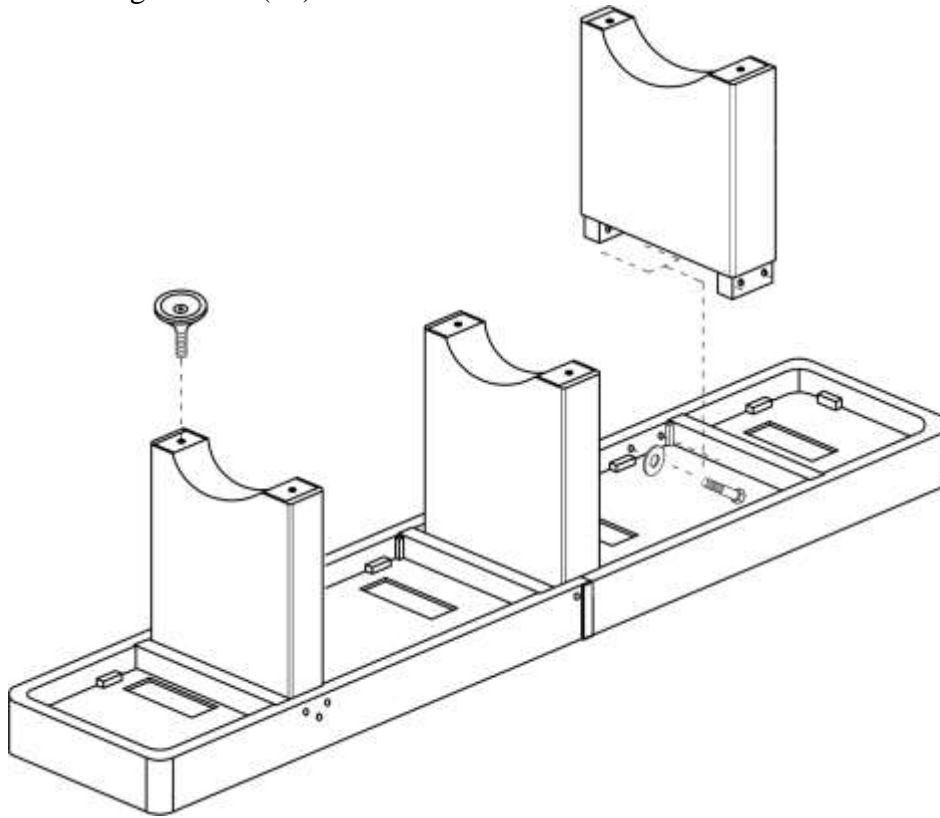

Place Cabinet in Position

1. Turn the cabinet right side up. *Take care not to rest the weight of the cabinet on the sides of the legs.
2. Optional: Attach the brass cover (#6) over the seam in the cabinet with screws (#7).

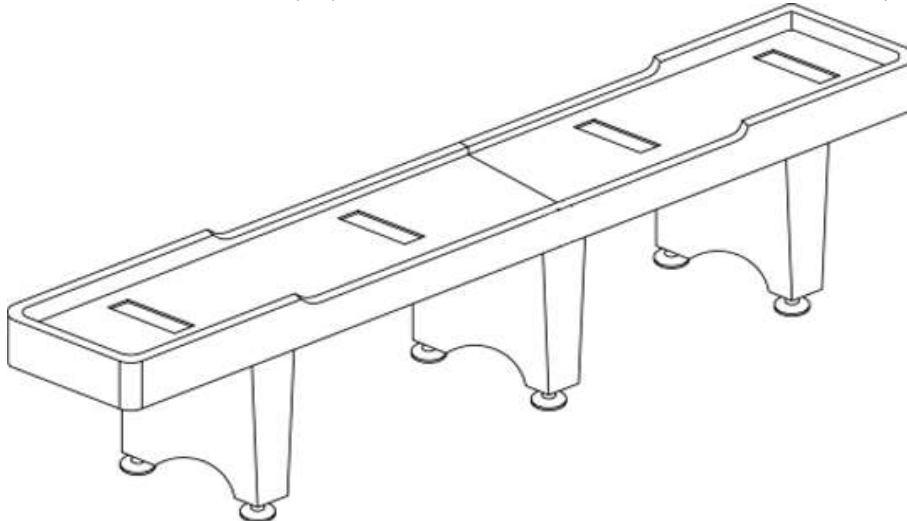

Assembly of the Play-board into Cabinet

*The weight of the play-board can be quite heavy so we suggest 2 to 4 people.

1. On smaller boards or if you have plenty of help then you can follow Method A below.

*Place board onto cabinet. Be sure to lift the board high enough so that the climate adjusters do not hit the cabinet.

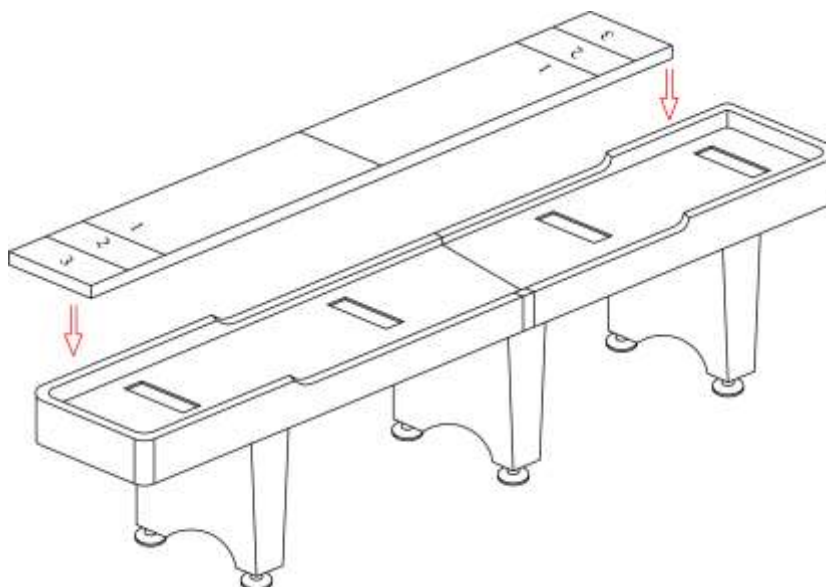

2. When working with larger boards or if you only have two people we suggest following Method B below.

*Place blankets or moving pads draped over one side of the cabinet and two pucks upside down on each end of the cabinet about 2" from where the end of the board is. Do not place them too far inside.

*Roll the board over upside down and rest half on the blanket and side of the cabinet.

*Roll the board on its edge inside the cabinet and carefully remove the blanket.

*Roll the board over right side up and rest it on the pucks.

*Have one person go under the table, and using the brackets as bars, bench press the end of the board while the other person removes the pucks.

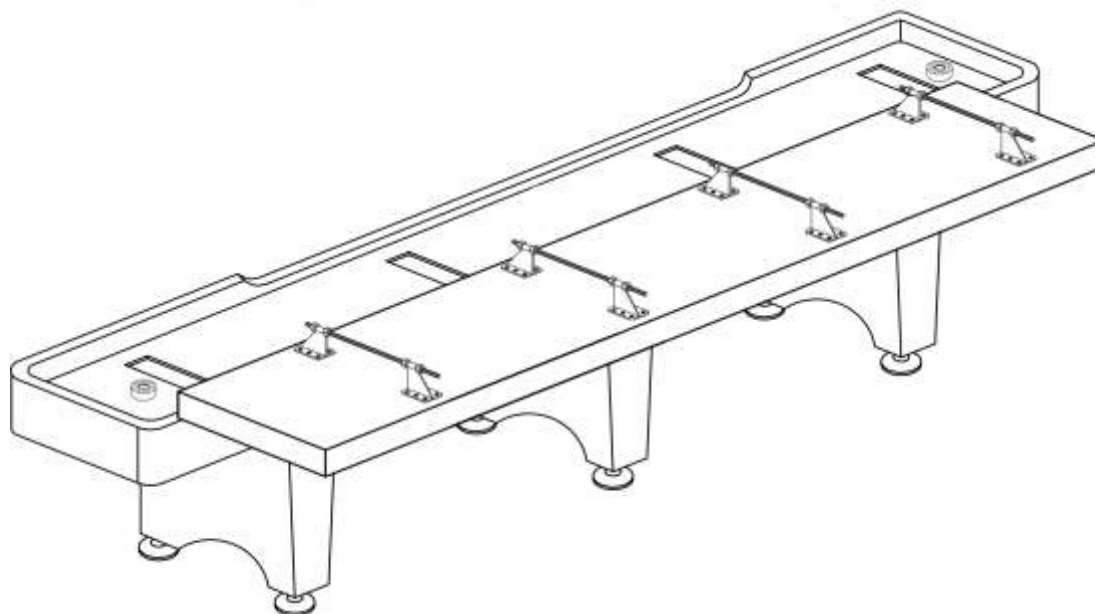

Leveling Tips and Maintenance Advice

1. Leveling the shuffleboard is best done with the drift of the pucks, not a level.
 - a. Adjust each end of the cabinet with the leg levelers slightly high so you have a sway or belly. This will keep the speed equal from end to end.
 - b. You have to judge if the drift of the puck is it going left to right because the table is low or is it the curve of the board. The best way to tell is to throw a puck down the right side trying to hug the rail, then the left side trying to hug the rail. If properly set, the puck at each end of the table should drift inward about 1-2 inches towards the center. This is a properly set concave board. If they fall off each outside edge the board is convex. If they drift inside on the right side but outside on the left side then your left leg is too low.
2. Prepare the board for play. The board was clean when it left our factory but still could have collected some dust in transit, so first use a multi-purpose surface cleaner or even a window cleaner and wipe off the dust on the surface of the table.
 - a. Silicone spray is not necessary but does speed up the board play. If you have purchased silicone spray with your table, apply a slight coat or mist then buff off with a soft cotton towel or rag.
 - b. Sprinkle a light coat of wax as even as possible, like a fresh snow fall.
 - c. Technically, you should play one game to 15 or 21 on one coat of wax. In tournament play the gullies collect a lot of wax. Players are allowed to throw dust from the gully before they shoot but may not re-wax the complete board until the end of the game.
 - d. After each game you should use a board sweep or brush to wipe the board clean and repeat the process.
 - e. If you use silicone spray it will only need to be applied before a big weekend game or tournament or once per month depending on play. After a period of time it may start to form build up. You should clean the board with a multi-purpose surface cleaner for polymer boards or we recommend Murphy's soap and water for traditional finish boards. Follow the instructions on the bottle and treat the board as any other fine piece of furniture.
3. Before they are prepared for packing and shipping, McClure Tables boards are set at the factory with a slight amount of tension on the climate adjusters towards the ends of the boards providing a slight concave or curve. That means the board is lower in the center more towards the end of the table. The pucks should break to the inside slightly.
 - a. 12-16 foot tables have four adjusters, and larger tables will have 6 to 8. When trying to adjust a board you should always start in the center and work towards the ends. The tension for concave should be greater towards the ends of the board as you want the puck to curve inside in the score zone but travel relatively flat in the center of the board.
 - b. It is best to not try to get it perfect the first day, let the board adjust to your climatic conditions a day or two then go back and fine tune the adjustments.

Convex Board

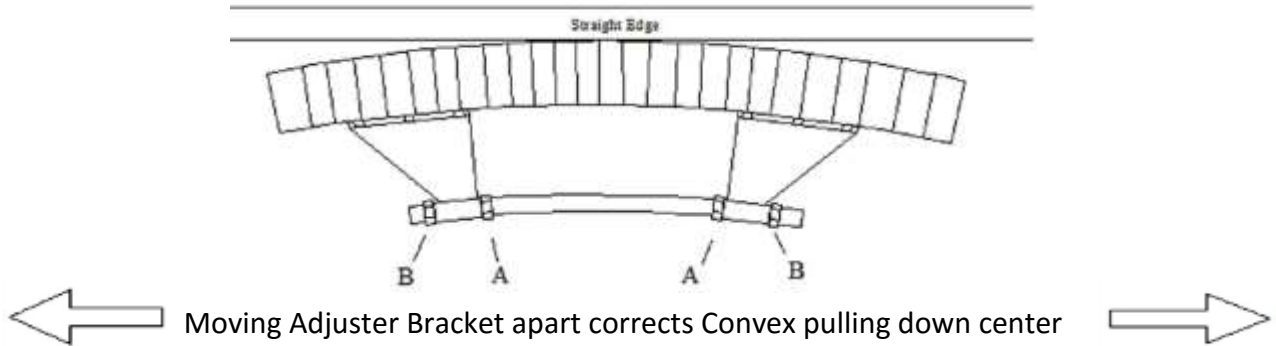

How to correct a Convex Board

(Note: Picture exaggerated for purposes of illustration)

- First, loosen Nut “B” completely.
- Second, using two wrenches on Nut “A” slowly turn towards the outside of the board. Be careful to do one or two turns at a time for a gradual uniform effect.
- Repeat this process a few times as necessary. An excessively convex board may need to be visited several days with a slight adjustment each day. Take care not to apply too much pressure, and if you hear any creaking of the board stop. Excessive pressure may crack a board, so please take care. When using a straight edge the board is flat when you cannot get a piece of paper under the center and the convex is gone when you cannot slide the paper under the sides.

Concave Board

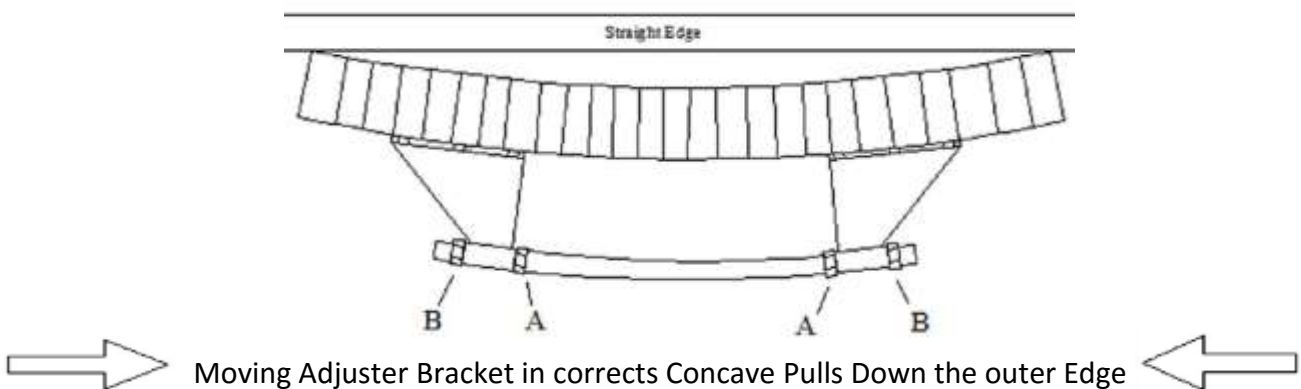

How to correct a Concave Board

(Note: Picture exaggerated for purposes of illustration)

- First, loosen Nut “A” completely.
- Second, using two wrenches on Nut “B” slowly turn towards the inside of the board. Be careful to do only one or two turns at a time for a gradual uniform effect.
- It may not take any turns of Nut “B” as the board is usually set with tension on it and simply by loosening the inside Nut “A” a half turn or so you may get the desired effect. Then you can tighten the nuts “B” just to lock the brackets into place tightly pinched between nuts “A” and “B”.

Please note:

- **When trying to adjust a board you should always start in the center and work towards the ends.**
- **It is best to not try to get it perfect the first day, let the board adjust to your climatic conditions a day or two then go back and fine tune the adjustments.**