

# Ludington Assembly Instructions

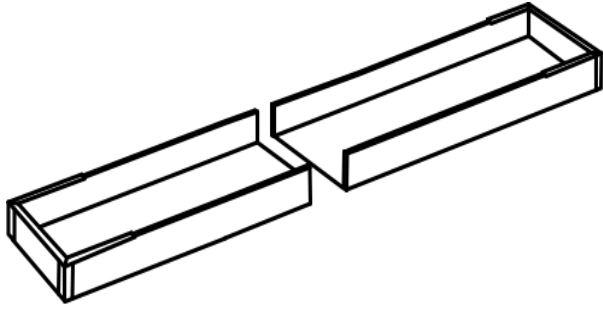

- Installation Instructions
  - Tables can be heavy we recommend 2 to 4 or more people for larger tables
  - Recommend power drill for uncrate or remove packing material
  - Most other assembly can be done with hand tools
  - Level or straight edge can be helpful.

# Ludington 12- or 18-foot Table Packing List



**#1  
2 Pc Cabinet**

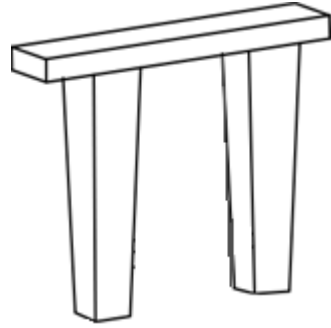

**#2  
3 Legs**



**#4  
2 Pcs Tight Joint Connector**



**#3  
6 Pcs Leg Levelers**

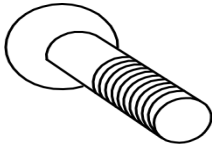

**#5  
12 Pcs 5/16 x 1.5" Allen Bolt**

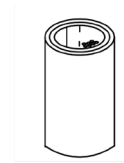

**1 Pound Can of Wax**

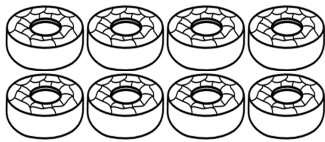

**4 Red Pucks & 4 Blue Pucks**

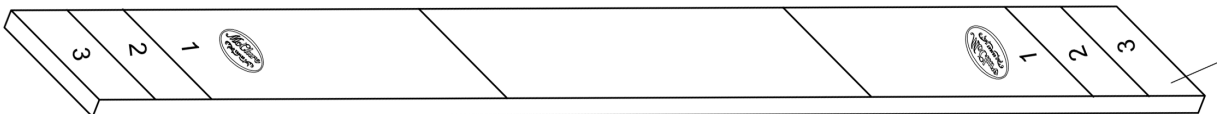

**2" Playboard**

## Assembly of the Legs and Cabinet

1. Attach leg levelers (#3) to the bottom of the legs.
2. Place the cabinet on its side on blanket or on soft carpet to prevent the cabinet from getting scratch or damaged.
3. Match the numbers that are stamp on the bottom side of the cabinet (one on each end and middle) with the ones that are stamped on the leg top plates.
4. Use # 5 Allen bolt to attach the legs to the table. Start with one half of the table. Put the end leg on first (**Make sure you have the angle of the leg facing out to the end of the table**). Then attach the middle leg with only two of the screw holes. When that half is secured carefully flip it so it is up right. **Careful not to put weight on the side of the leg when flipping it up right**. Repeat for the other half of the table by putting to end leg on and flipping the table over and lining the two halve together. When the halves are lined together use the tight joint # 4 to secured the two halve of the tables together. Then finish by putting the last two Allen bolt # 5 in the middle leg. Now you can level you table.

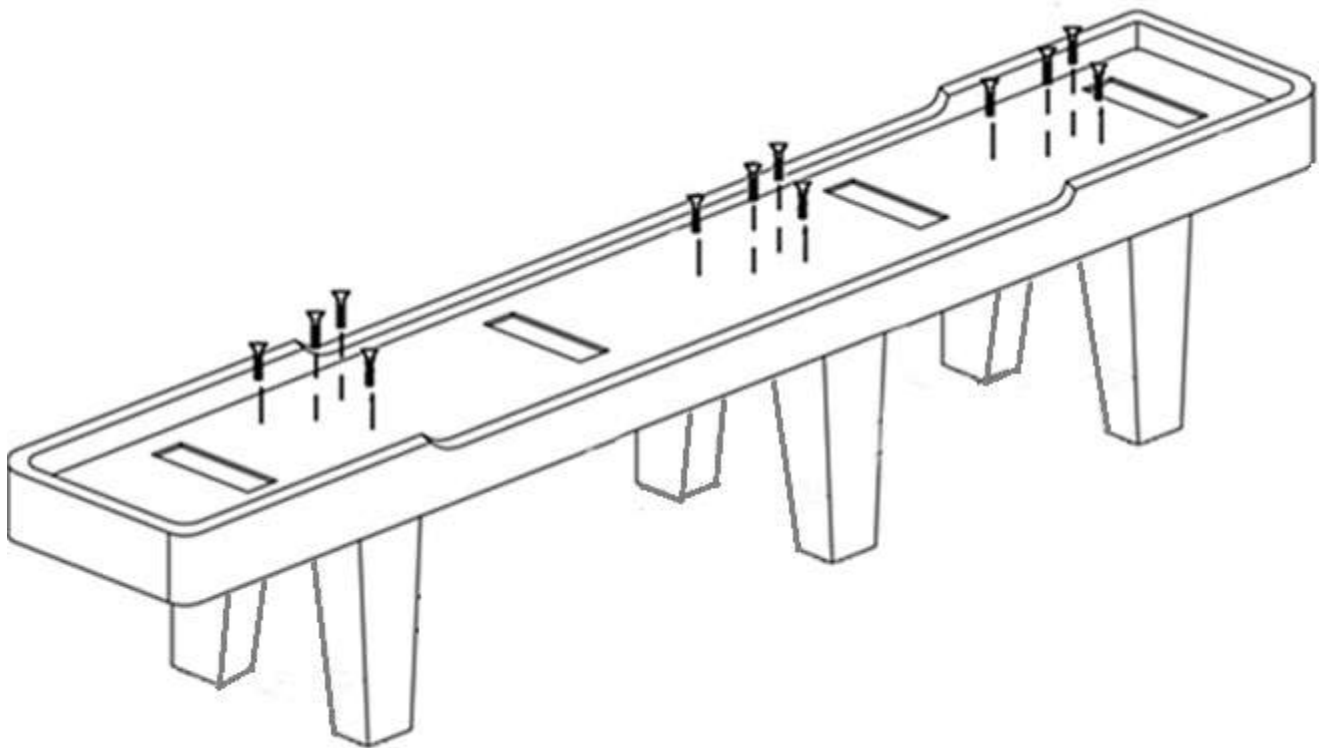

## Assembly of the Play-board into Cabinet

\*The weight of the play-board can be quite heavy, so we suggest 2 to 4 people.

1. On smaller boards or if you have plenty of help then you can follow Method A below.

\*Place board onto the cabinet. Be sure to lift the board high enough so that the climate adjusters do not hit the cabinet.

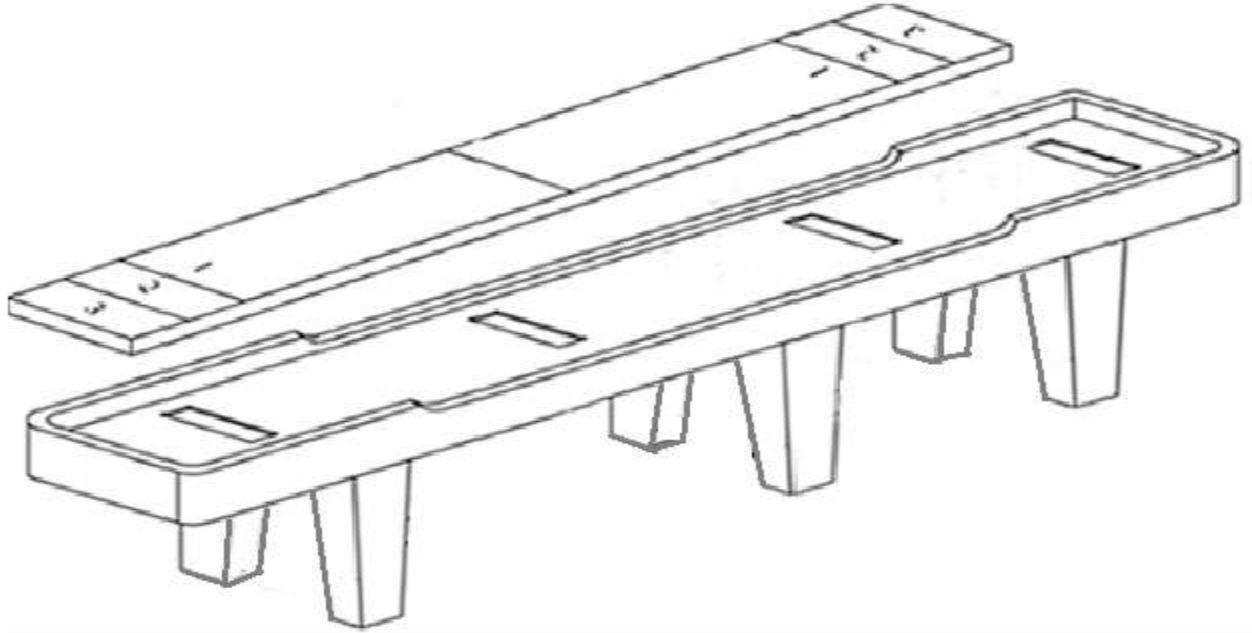

2. When working with larger boards or if you only have two people, we suggest following Method B below.

\*Place blankets or moving pads draped over one side of the cabinet and two pucks upside down on each end of the cabinet about 2" from where the end of the board is. Do not place them too far inside.

\*Roll the board over upside down and rest half on the blanket and side of the cabinet.

\*Roll the board on its edge inside the cabinet and carefully remove the blanket.

\*Roll the board over right side up and rest it on the pucks.

\*Have one person go under the table, and using the brackets as bars, bench press the end of the board while the other person removes the pucks.

